

I4-technology LLC

Innovative dog repeller "Dog STOP Flash +"

User manual
INTK.433523.002 RE



CONTENTS

1 Device description and operation.

1.1 Device application.

1.2 Technical specifications.

1.3 Device components.

1.4 Structure and functioning.

2 Intended use.

2.1 Operating restrictions.

2.2 Device usage.

2.3 Recommendations for a dog attack prevention.

3 Maintenance.

3.2 Current repair. Troubleshooting

4 Packaging, storage and transportation.

5 Acceptance Certificate.

6 Manufacturer warranty.

The User Manual includes key features, operating instructions (intended use, maintenance, repair, storage and transportation) of innovative repeller "Dog STOP Flash +" (hereinafter - device).

The device is designed for effective protection against stray dogs' attacks, as well as for use as a high brightness torch at night. Device effectiveness is achieved by application of the advanced impact factors: unique pattern of the ultrasonic sound and bright flashes.

The number of stray dogs is constantly increasing. Nobody is safe from a meeting with an aggressive pack of dogs. Sometimes dogs do not allow you to pass by and, unfortunately, stone or stick does not happen to be in your hand at the same moment. The device will help you in such a difficult and dangerous situation.

Before using the device, please, carefully read the supplied User Manual.

Following the instructions, restrictions and guidelines contained in User Manual will extend the life of the device and allow you to use it most effectively.

Violation of the storage instructions and operating rules will lead to manufacturer warranty termination.

1. DEVICE DESCRIPTION AND OPERATION.

1.1. Device application.

1.1.1. It is a portable device designed to deter aggressive dogs by high frequency sound signals and bright flashes. It could also function as a light torch. Besides self-defense, the device can be used to protect your pet from strange or stray dogs. It also can function as a dog-training device.

1.1.2. Device operating instructions:

- surrounding air temperature, °C from – 40 to + 55;
- relative air humidity at 25°C, % up to 98;
- atmospheric pressure from 66,6 kPa up to 106,6 kPa (from 500 mmHg up to 800 mmHg).

1.2. Technical specifications.

1.2.1. Visual appearance of the device is shown on Figure. 1.



Figure 1. – Visual appearance of the device.

1.2.2. Dimensions, mm.....110x57x35

- 1.2.3. Weight, including batteries, kg.....0,1
- 1.2.4. DC supply voltage (3 batteries AAA), V..... from 2,5 up to 4,5
- 1.2.5. Maximum current consumption by the device, mA..... **340 mAh**
- 1.2.6. Effective distance, m.....10 (20)
- 1.2.7. Sound pressure level at 1 m distance from the device, dB..... 120 ±1
- 1.2.8. Triple expelling effect: ultrasound + flash lights + unique pattern of ultrasonic signals
- 1.2.9. Functional modes2 (expelling, torch)
- 1.2.10. Digital stabilization system of power level.....incl.
- 1.2.11. Automatic activation of expelling signalincl.
- 1.2.12. Number of power control levels4 (LED display colors: green, orange, red or off)

1.3. Device components

1.3.1. Device components and supplied package are shown on Table 1.

Table 1.

№	Description	Quantity	Comment
1	Innovative repeller "Dog STOP Flash +" TS 6329-004-64062607-2012	1	
2	Batteries type AAA	3	Installed in the device
3	Belt clip	1	
4	Self-tapping crews of fastening clip	2	
5	Individual package	1	
6	User Manual INTK.433523.002 RE	1	
8	Quality checklist	1	

1.4. Structure and functioning

1.4.1. Location of repeller's main parts is shown in Figure 2.

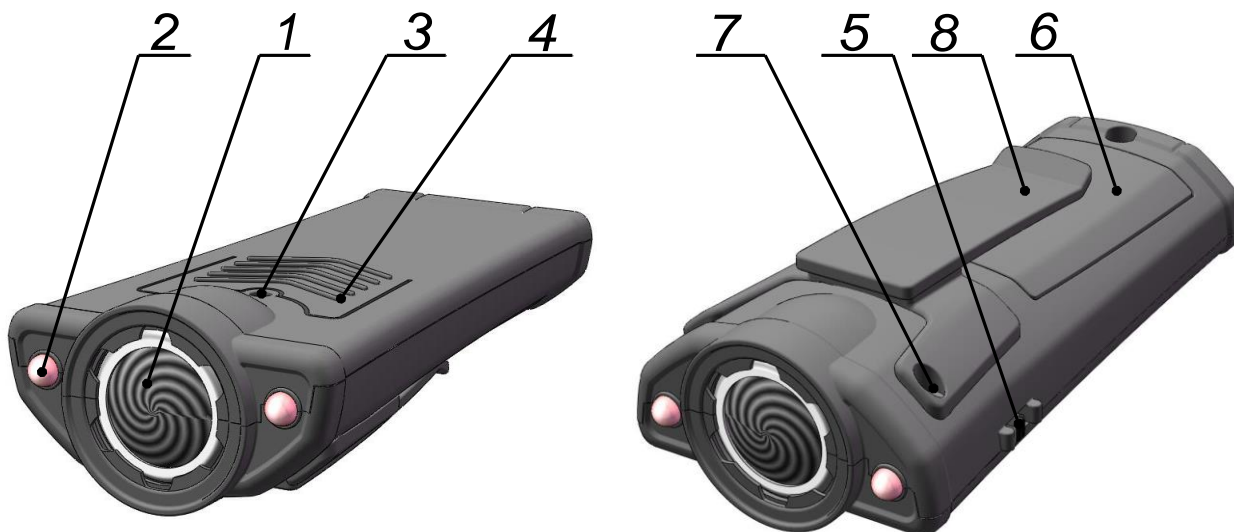

- 1 – ultrasound transducer*
- 2 – high brightness LED*
- 3 – LED indicator for battery power and display*
- 4 – power button*

- 5 – *light torch switch on slider*
- 6 – *battery cover*
- 7 – *self-tapping screws for case fixing*
- 8 – *belt clip*

Figure 2. – Parts assembly

1.4.2 The housing is constructed of high impact ABS plastic.

1.4.3 Belt clip (item 8 on Figure 2) is designed for user convenience. It can be installed on the belt with the help of two self-tapping screws of extended length that are supplied in the package. Scheme of clip installation is shown on Figure 3.



Figure 3 – Scheme of clip installation

1.4.4 The device runs under command of microcontroller with embedded software.

1.4.5. Device transducer (item 1 on Figure 2) emits special high frequency sound waves (pattern of the sound is determined by software in accordance with the customized algorithm) with the sound pressure reaching 120 dB at 1 m distance from the transducer. Ultrasonic waves generated by the device produce a depressing effect on aggressive dogs, causing them to feel panic with an overwhelming desire to leave the repeller coverage zone as quickly as possible. Additionally the device emits high brightness flashes of white light, which intensify the expelling effect.

1.4.6. If necessary, the device can be used as high brightness light torch. All you need is to switch the slider (item 5 in Figure 2) to the ON position.

1.4.7. The device is powered by 3 batteries type AAA which are placed in battery compartment. There is an installation scheme inside the battery compartment that shows the right way to install the batteries.

2. INTENDED USE.

2.1. Operating restrictions.

2.1.1. This product is designed to protect you from aggressive dogs! Only in this case the maximum efficiency of the device could be reached! It also can function as a dog-training device.

2.1.2. Do not cover or block the ultrasonic transducer that is located behind the grid. Damage of the transducer may cause improper operation of the device or render it unusable.

2.1.3. Do not point the light torch directly at person's eyes.

2.1.4. Do not hold the running device in close proximity to person's ears - this may cause headaches and temporary hearing loss.

2.1.5. Do not put your hand or clothing on ultrasonic transducer while it's operating in expelling mode.

2.1.6. The device is ineffective against the deaf animals.

2.1.7. Children should not use the device without parental supervision.

2.1.8. Do not test the device on dogs that behave friendly. This could provoke them.

2.1.9. Do not test the device on dogs in closed, small spaces (elevator cabs, pantries, etc.) – Dog may react inappropriately.

2.1.10. Do not test the device on dogs that are guarding their territory.

2.1.11. Do not test the device on your own pets. This could provoke them.

2.2. Device usage.

WARNING! Before first use of the device, make sure that the batteries have sufficient charge. All you need is to press switch on button. Battery charge LED should be green!

2.2.1. Expelling mode.

Point the device at an aggressive dog. Press and hold the power button (item 4 in Figure 2). The device will automatically begin to emit ultrasonic sound waves and flashes of light according to a defined program algorithm. Program derives the most effective combination of ultrasonic sounds and flashes of light that will deter an aggressive dog. Wait 1-5 seconds before you see the effect.

The device emits a directed ultrasonic sound. Therefore, the effectiveness could be reduced if the device is directed at an angle to the dog. Change slightly the angle of the device in order to find the most efficient zone that will be mostly unpleasant for the dog.

The maximum impact range of the repeller is 20 meters, but the most effective expelling range - 1-7 meters. In this case, the standard behavior of the dog is to back off or run away.

2.2.2. High brightness light torch mode.

In order to use the device as a light torch switch the slider (item 5 in Figure 2) to ON position. To turn off the light torch switch back the slider into position OFF.

While the device is in operation it is important to monitor the battery charge level*. If the battery LED indicator (item 3, Figure 2) starts to glow red, replace the batteries with the new ones. To do this, press the latch on the battery cover and open the compartment. Remove dead batteries and install new, keeping polarity as indicated on the inside of the battery compartment. Close the battery compartment. The device is now ready to work.

** For the more effective and extended operation of the device it is recommended to use alkaline batteries of the famous manufacturers.*

2.2.3. Mode indicator and battery charge level LED.

When you press power button of the device the LED (item 3) should be green. That means that the battery charge is sufficient, expelling mode is ON and the device is working properly.

When you press power button of the device and the LED (item 3) is red that means that the batteries are dead.

2.3. Recommendations for dog attack prevention.

The device is recommended to use only in case of a real threat of an aggressive, stray or guard dog attack.

2.3.1. How to tell if a dog is acting aggressive?

It is not hard to identify such a dog's behavior.

The first sign of aggressive behavior – a dog is showing teeth. Note that the more aggressive a dog is, the more its front teeth are exposed. If a dog is acting aggressive, its hackles is raised. Aggressive behavior is commonly associated with still and sharp look into the eyes of the enemy. In this way a dog is challenging you.

If the dog is ready to attack, its front paws are put wider, head is held up, and the muzzle is slightly down.

2.3.2. How not to provoke an aggressive response?

When you cannot run away and the dog just started to expose aggression without attacking, you should try to "neutralize" its aggression. It is important to be still and calm. Take maximum of your self-control. No adrenaline – a dog will sense it and may become excited. Stay calm and try not to pay attention to a dog. Your posture should expose calmness and indifference to a dog. Do not look straight into dogs' eyes. Do not turn in its direction. Do not make any sudden movements. Do not show your fear. Watch the dog only by peripheral vision: show that you are not trying to intrude its territory; you are busy with your own affairs. In this way, a dog will not assume that you are intruding its territory, its place in the pack, its food, etc. Never try to run away otherwise it will provoke a dog attack! Usually, when a dog attacks with barking, it means a minor threat. Most likely, it just wants to scare you, to chase you away from the territory where you stand. Still be on guard because theoretically a dog may be likely to attack.

3. MAINTENANCE.

3.1. Maintenance requires only replacing of batteries (see Section 2.2.1), as well as cleaning the surface of the device.

3.2. Current repair. Troubleshooting.

Typical problems and possible solutions are specified in Table 2.

Table 2

Problem	Possible reasons	Possible solution
When you turn on the device the battery indicator is not lit, the light torch LEDs do not lit.	Batteries are dead	Replace batteries
	Batteries are not properly installed	Install batteries in accordance with polarity
	Device is defective	Take the device to service center

4 PACKAGING, STORAGE AND TRANSPORTATION.

Each device is packed in individual package according to the supply package as indicated in Table 1.

Product moving in the package is not allowed.

Packed devices are placed into shipping containers - a corrugated fiberboard box (State Standard 22637).

Packaged devices can be transported by vehicle or railway in covered trucks or containers, by air in pressurized compartments.

During transportation packed packages should be protected from precipitation and direct sunrays.

Transportation conditions:

- surrounding air temperature: from -50 up to 50 °C;

- relative humidity up to 95 % at 25 °C;

- atmospheric pressure from 84 up to 107 kPa (630 - 800 mmHg)

- shock acceleration peak value is up to 147 m/s² (15 g), with a duration of shock acceleration 10 ... 15 ms

The requirements on warning signs must be strictly obeyed when loading and transportation

5 ACCEPTANCE CERTIFICATE.

Innovative repeller "Dog STOP Flash +" TS 6329-004-64062607-2012

Serial number _____

Manufacture date _____

Manufactured and accepted in accordance with the applicable technical documentation and validated.

Quality Department stamp _____

6 MANUFACTURER WARRANTY

6.1 The manufacturer guarantees that the device is manufactured in accordance to TS 6329-004-64062607-2012 provided the operation, storage and transportation conditions are observed. Conditions are specified in the operational documentation.

6.2 Effective device duration period — not less than 5 years

6.3 Manufacturer warranty - 12 months from the date of purchase.

6.4 If the device fails during the warranty period, the supplier (manufacturer or companies providing maintenance services) should replace or repair it at its own expense.

6.5 Customer loses the right to obtain warranty service in the following cases:

- After warranty term expiration;
- Violation of the operation, transportation and storage instructions;
- Mechanical damages causing device failure after the purchase;
- Manufacturer sealing is broken.

6.6 Repair and maintenance of devices with an expired warranty period is covered at the customer's expense.



Manufacturer's technical support:

www.i4technology.ru

© Copyright I4 technology LLC, 2005-2013.

All rights reserved.



Warranty Certificate

Product: Innovative repeller "Dog STOP Flash +"

Serial number _____

--	--	--	--	--	--

--	--	--	--

Manufacture date _____ ● _____

Quality Department stamp _____

Date of purchase _____

Seller's signature and stamp _____

I do not have any claim against quality of the device, its package and technical state _____
(Customer's signature)